



U.S. Department of Energy

National Transportation Program



Spent Nuclear Fuel and High-Level Radioactive Waste Transportation

Typical Commercial Reactor Fuel Assembly

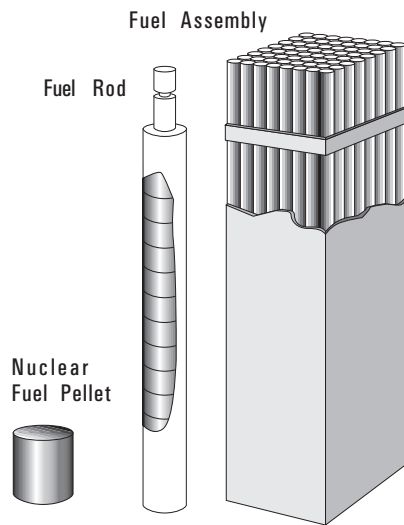

The fuel for commercial nuclear power plants consists of small pellets, stacked in rods approximately 12 feet long. The fuel rods are grouped in fuel assemblies located in the core of a nuclear reactor that generates the power to produce electricity. Research reactor fuel is shorter and typically consists of metal-clad plates or cylinders (aluminum and TRIGA fuel).

* Training, Research, Isotope production, General Atomics

Typical Research Reactor Fuel Elements

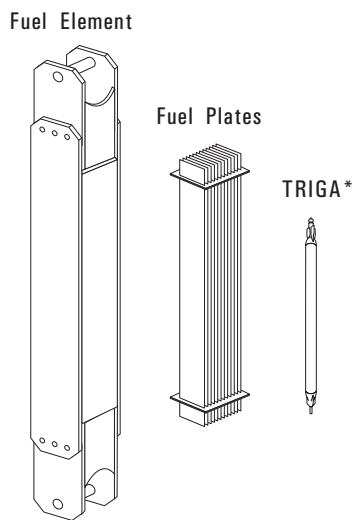

countries for peaceful atomic use. These shipments to the United States are part of an ongoing policy and treaty agreements made in the 1950's under President Eisenhower.

What Is Spent Fuel?

Spent fuel comes from commercial nuclear power plants, foreign and domestic research reactors, and nuclear powered U.S. Navy warships. After the fresh fuel has been used in a reactor, highly radioactive spent fuel assemblies remain. The assemblies must be removed from the reactor for storage to make room for new assemblies and to allow the fuel to cool. Currently, most spent fuel assemblies are stored in pools of water, aboveground vaults, or concrete casks.

The U.S. Department of Energy (DOE) ships highly radioactive materials between former production sites, research reactors, power reactors, storage, and other facilities throughout the United States. Two types of highly radioactive materials are spent fuel and high-level radioactive waste that resulted from reprocessing spent fuel. Because separated highly enriched uranium could

be used in nuclear weapons and because the United States has established a policy to eliminate the proliferation of weapons grade materials, DOE no longer reprocesses spent fuel. As part of U.S. nuclear nonproliferation initiatives, DOE also accepts shipments of spent fuel from foreign research reactors. This spent fuel contains uranium enriched in the United States that was provided to foreign

Spent fuel also results from DOE-owned research and defense reactors, from reactor design testing, and from energy and medical research. Like spent fuel from power plants, DOE spent fuel is temporarily stored where it is produced or shipped to another temporary storage site.



Spent fuel is often transported to storage facilities by rail.

waste must be isolated from the environment for thousands of years until the radioactivity has decreased to a safe level. High-level radioactive waste is currently stored in underground tanks and vaults at government sites. Some high-level waste is being immobilized in glass logs at the Savannah River Site.

Why Are Spent Fuel and High-Level Radioactive Waste Shipped?

Spent fuel is shipped to temporary storage sites when space at reactors is limited. This action implements the nonproliferation policy for foreign fuels and provides temporary storage for naval propulsion fuels. DOE will be responsible for the transportation of spent fuel and high-level radioactive waste from commercial nuclear power plants, DOE storage sites, and defense-related high-level radioactive waste sites, to a permanent geologic repository for disposal, if sited.

What Is High-Level Radioactive Waste?

High-level radioactive waste results from the reprocessing of spent nuclear fuel. It includes liquid waste produced directly during reprocessing and solid material derived from such liquid waste that contains fission products in sufficient concentrations. Other highly

radioactive materials determined by the U.S. Nuclear Regulatory Commission (NRC) to require permanent isolation are also considered high-level waste. The United States does not currently reprocess spent fuel from power plants but has reprocessed spent fuel from many types of reactors in the past. As with spent fuel, high-level radioactive

Spent Nuclear Fuel Being Shipped to or Stored at DOE Facilities*

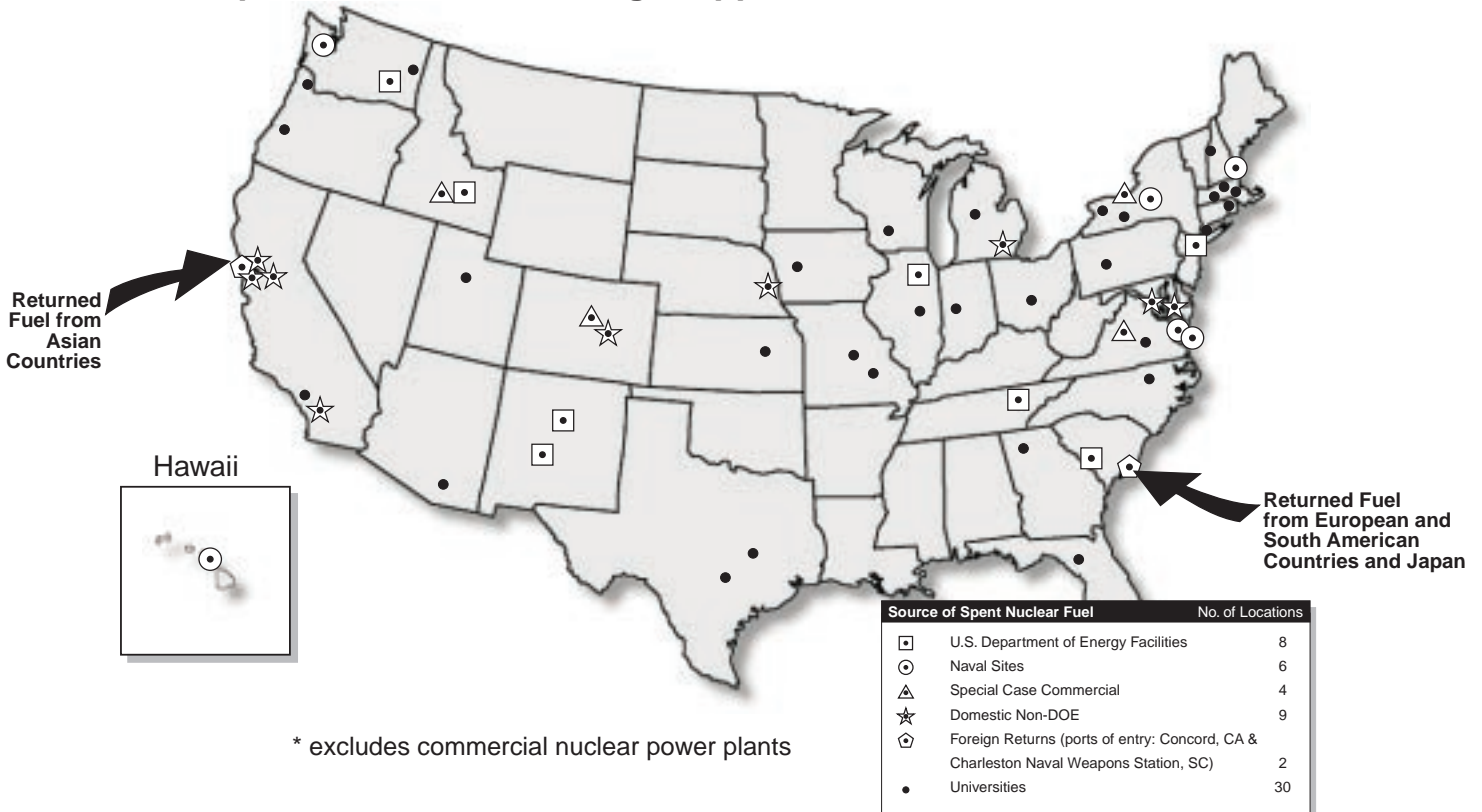

Sequence for Physical Testing of Type B Packaging Designs*
(as listed in 10 CFR 71.73)

How Are Spent Fuel and High-Level Radioactive Waste Shipped?

Spent fuel and solid high-level radioactive waste are packaged in specially designed shipping containers (Type B packagings) called casks and transported by truck, train, or ship. Type B packages provide shielding against the energy (radiation) emitted by the radioactive materials and provide a barrier to release of the radioactive material itself. These packagings are the most robust (sturdy) available for radioactive materials transport. Type B packaging designs are certified by the NRC to minimize risks under both routine transport operations and severe accident conditions. DOE self-certifies some packagings for national security shipments.

How Does DOE Minimize Risk?

All personnel (including carriers and shippers) involved in preparing shipments follow required procedures and are trained in the regulations to help ensure shipment safety. DOE must meet the strict performance standards and testing requirements established by the NRC for packaging designs used to ship spent fuel and high-level radioactive waste. Computer analysis and scale model testing demonstrate compliance with the standards. In some cases, full-scale testing is required by NRC to demonstrate compliance.



Spent nuclear fuel and high-level radioactive waste are transported internationally by ship.

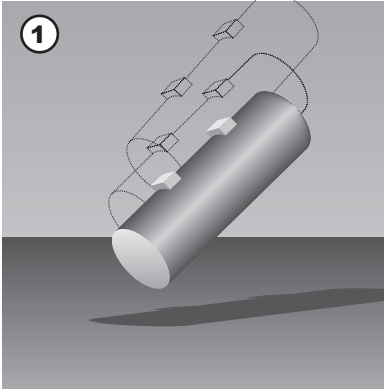

1

Free Drop (Impact): A 30-foot drop onto a flat, unyielding** surface so that the package's weakest point is struck.

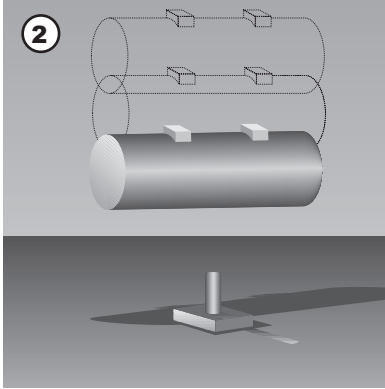

2

Puncture: A 40-inch free drop onto a 6-inch diameter steel rod at least 8 inches long, striking the package at its most vulnerable spot.

Crush: For some low-density, light-weight packages, a drop of a 1,100-pound mass from 30 feet onto the package resting on an unyielding surface is required.

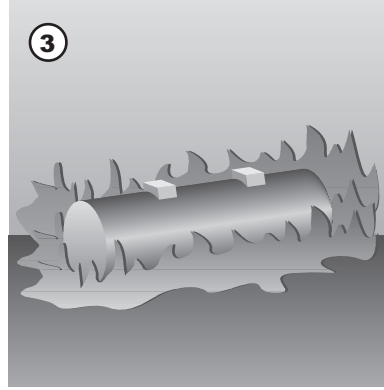

3

Heat: Exposure of the entire package to 1,475°F for 30 minutes.

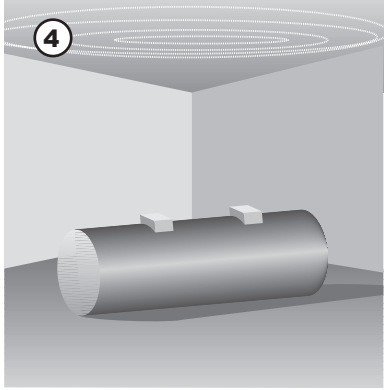

4

Immersion (fissile materials): Package immersed under 3 feet of water in a position where maximum leakage is expected.

Immersion (all packages): A separate, undamaged package is submerged under 50 feet of water.

10 CFR 71.61 requires irradiated nuclear fuel packages to be subjected to pressure that relates to a water depth of greater than 600 feet.

* Documentation is required that each design can meet the test conditions. Individual packagings are not tested before each use.
** Using an unyielding surface ensures that damaging energy created by the impact will be absorbed by the package rather than the surface.

U.S. Department of Transportation (DOT) regulations for highway shipments of spent fuel and high-level radioactive waste were established to minimize risks associated with radioactive materials transportation. These regulations require carriers to select routes that reduce time in

transit. State or Tribal routing agencies may select alternate routes that comply with DOT guidelines. DOT regulations cover packaging, labeling, marking, shipping papers, and other measures intended to promote the safe transport of radioactive materials.



DOT regulations cover packaging, labeling, marking, placarding, shipping papers, and other measures intended to minimize the risks associated with the transport of radioactive materials.

Rail shipments can reduce risk and increase safety. Routes for rail shipments are selected to minimize time in transit and interchange points, to use best available trackage, and to promote schedule efficiency. Water shipments are impacted by currents, weather conditions, and geographical features that limit the number of oceanic routes available to shippers and carriers.

In addition, DOE consults and coordinates transportation planning with States, Tribes, the carrier, and other Federal agencies. As part of this effort, DOE, States, and Tribes can track spent

fuel and high-level waste shipments with the DOE computer-based satellite tracking system called TRANSCOM. This enables DOE and State/Tribal emergency teams to follow shipment progress.

What If a Transport Accident Occurs?

As with any transportation accident involving hazardous materials, in the event of an accident involving a spent fuel or high-level radioactive waste shipment, local, State, and Tribal fire and police organizations would be the

first to respond. DOE maintains Radiological Assistance Program teams of specially trained experts to support State, local, and Tribal first responders with radiological monitoring and technical assistance and advice.

Summary

Federal regulations govern all aspects of packaging and transportation to promote the safety of spent fuel and high-level radioactive waste shipments. No injuries or fatalities have resulted from the radioactive contents of DOE shipments.

Additional information on DOE's National Transportation Program may be obtained from:

National Transportation Program
U.S. Department of Energy
Albuquerque Operations Office
P.O. Box 5400, MS SC-5
Albuquerque, NM 87185-5400

Phone : 505-845-6134
Fax: 505-845-5508

Website:
<http://www.ntp.doe.gov/>

DOE Center for Environmental
Management Information
P.O. Box 23769
Washington, DC 20026-3769

1-800-7EM-DATA
1-800-736-3282

Website:
<http://www.em.doe.gov/>

Transportation Resource Exchange Center
ATR Institute
University of New Mexico
1001 University Blvd., SE
Albuquerque, NM 87106-4342

Phone : 1-877-287-TREX (8739)
Fax: 505-246-6001
email: trex@unm.edu

Website:
<http://www.unm.edu/~trex>